

Ethernet Industrial I/O Module Hardware Manual

Model 2426 | Rev.A | September 2008

SENSORAY | embedded electronics |



Designed and manufactured in the U.S.A.

SENSORAY | p. 503.684.8005 | email: info@SENSORAY.com | www.SENSORAY.com

7313 SW Tech Center Drive | Portland, OR 97223

Chapter 1: Quick Setup Guide

1.1 Overview

Each 2426 module is assigned a unique IP address, netmask and gateway. These parameters may be configured by following the directions given below. By assigning a unique IP address to each module, it is possible to connect a virtually limitless number of modules to a network.

1.2 Select Network Addresses

1. **Choose a temporary IP address** for the 2426 module. This address must be compatible with the network that will be used to configure the module, and it will only be used during the configuration process.

Make sure the temporary address you choose is not used by another host on the configuration network.

Example:

Your configuration network is 192.168.0.0 with netmask 255.255.0.0. The only other hosts on this network are your PC at 192.168.1.2 and a router at 192.168.1.1. In this case an arbitrary, unused address such as 192.168.1.25 may be used for the module.

2. **Choose a permanent IP address** for the module. This is a static address that will be permanently assigned to the module unless you manually change it again later. The permanent address must be compatible with the network to which the module will be attached in your application.

Make sure the permanent address you choose is not used by any other hosts on the target network. The permanent address may be the same as the temporary address (in step 1, above) if the module is being configured on the target LAN.

Example:

Your target network is 10.0.0.0 with netmask 255.0.0.0. In this case you could assign an arbitrary, unused address such as 10.1.2.3 to the module.

1.3 Configure the Network Interface

1. **Connect the module to your configuration LAN** with an Ethernet patch cable, Category-5 or higher. Use a crossover cable if you are connecting the module directly to a computer, otherwise use a standard patch cable.
2. **Apply 24VDC power** to the module.
3. **Switch to Configuration mode.** Hold down the module's CONFIG pushbutton while you press and then release the RST pushbutton. The blue LED under the CONFIG pushbutton will light when the module is in Configuration mode. If multiple modules are connected to your network, ensure that only one module is in Configuration mode.

4. **Program the temporary IP address.**

Run ARP with this command line:

```
arp -s <temp_addr> 08-00-56-FF-FF-FF
```

Example:

```
arp -s 192.168.1.25 08-00-56-FF-FF-FF
```

Windows

You can do this in either of the following ways:

- Navigate to Start | Run, then type the command into the dialog box and click OK.
- Open a console window, then type the command at the shell prompt followed by Enter.

Linux

Open a shell, then type the command at the shell prompt followed by Enter.

5. **Open this URL** from a web browser:

```
http://<temp_addr>/config.htm
```

Example:

```
http://192.168.1.25/config.htm
```

The module's Configuration web page should appear in your browser window.

6. **Program the permanent network settings.** In the designated field on the Configuration web page, enter the permanent IP address you chose earlier. If necessary, also enter a new netmask and gateway address. Click the Submit button and wait for the page to reload.
7. **Reset the module.** Press and release the RST pushbutton. Your permanent network settings are now in effect.

Chapter 2: Introduction

2.1 Overview

Sensoray's Model 2426 is a compact electronics module that performs I/O interface services for Ethernet clients. A variety of interfaces are implemented on the module including:

- Analog output (AOUT).
- 6 analog inputs.
- 8 optically isolated, general-purpose digital inputs.
- 16 general-purpose digital outputs (DOUT) with integral routing system for safety interlocks.
- Incremental encoder interface.
- Serial RS-422/485 communication port.

The module includes a number of hardware features that are designed to simplify its integration into host systems: it is compact, it requires only a single 24VDC power source, and it can be quickly installed by simply snapping it onto a standard din mounting rail. The module's software interface is simple, too: I/O services are provided over Telnet for automated applications, and HTTP for diagnostic and manual control.

Figure 1: Block Diagram of the 2426 Module

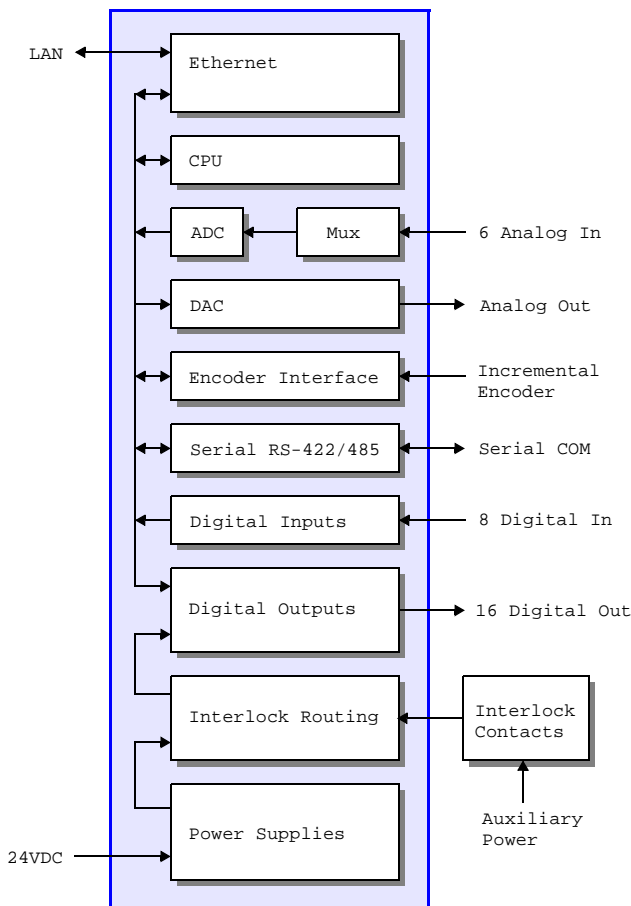

A typical system consists of one or more 2426 modules, one or more associated power supplies, a host computer running a control and/or monitoring program, and a local area network (LAN).

In the simplest case, the LAN may consist of a crossover cable that connects a host directly to a single 2426 module. In more complex systems, each 2426 module will typically connect to a network switch or router, which in turn provides access to the module from one or more host computers.

2.2 Status LEDs

Numerous LEDs reside on the module to give a comprehensive visual indication of the state of the module and its various interfaces. Each LED is labeled on the module silkscreen to indicate its function.

 This symbol is placed next to descriptions of the module's LED status indicators.

2.3 Heartbeat

A "heartbeat" LED flashes several times per second as an indication that the module's internal CPU is functional and various other resources are operating within error limits.

 **HBT** lights periodically to indicate the module's internal control systems are operating normally.

2.4 Module Reset

2.4.1 RST Pushbutton

The module will immediately execute a hardware reset when the RST pushbutton is pressed.

 **RST** lights briefly while the module is being reset.

2.4.2 CONFIG Pushbutton

The module will enter its Configuration mode if the CONFIG pushbutton is pressed while RST is pressed and then released. While in the Configuration mode, the module's network interface assumes a known MAC address and its servers listen at all IP addresses. See Chapter 1 for details.

 **CONFIG** lights when the module is in Configuration mode.

2.4.3 Module State Upon Reset

Upon power-up, or in response to a hardware or software reset, all module outputs are forced to known states:

- All DOUTs are all set to their inactive states and are configured to operate in the Standard (vs. PWM) operating mode.
- AOUT is set to zero volts out.
- The COM interface ceases transmit operations and all communication queues are flushed.

2.5 Safety Features

Model 2426 features several special mechanisms that can be used to enhance the safety of application systems:

- A hardware watchdog timer forces a hardware reset in the event of a malfunction by the module's internal CPU, thus forcing all outputs to their "safe" states.
- A communication watchdog timer generates a software reset if a network client ceases to communicate, thus forcing all outputs to their "safe" states.
- All DOUTs incorporate interlock chaining to ensure fail-safe shutdown when associated safety interlock contacts are open. By implementing this essential function within the module, system complexity and cost is reduced due to reduction of wiring and external termination boards.

2.6 Timestamps

A high-resolution timestamp generator is implemented on the module to circumvent some of the timing limitations incurred when passing real-time data over networks.

A timestamp value is attached to all encoder and analog input data so that the application can know when sampled data was acquired.

2.7 Module Layout

Figure 2 shows the locations of all application connectors and user-installed configuration posts on the module.

Figure 2: Module Layout

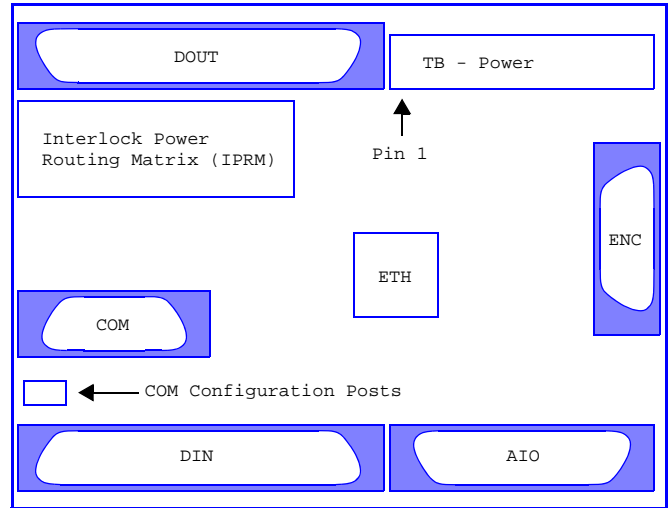

2.7.1 Connectors

The connectors in Figure 2 are abbreviated as follows:

- AIO — Analog inputs and output.
- COM — Serial RS-422/RS-485 communication port.
- DIN — General purpose digital inputs.
- DOUT — General purpose digital outputs.
- ENC — Incremental encoder interface.
- ETH — Ethernet interface.
- TB — Power terminal block.

The 2426 module incorporates robust, two-piece mating connectors for field wiring (see Figure 2). All connectors have mechanical detentes or provision for hold-down fasteners to help maintain solid connections in high-vibration environments. Except for the power TB, mating connectors are not supplied with the module.

Several connectors are reserved for manufacturing and test. Applications should not make electrical connections to these connectors: JP11, P3 and P5. Also, a shunt must be installed at JP12; it is removed only for factory programming and test.

Chapter 3: Power

3.1 Terminal Block

A pluggable terminal block (connector “TB” in Figure 2) is used to connect power to the module.

Table 1: Terminal Block Pin Assignments

Pin	Name	Function
1, 2	GND	Return for the +24VDC power supply that is connected to pin 3 or 4. One of these must be connected to the 24VDC power supply return, while the other may be used to route incoming GND out to an external load.
3, 4	+24V	+24VDC operating power for the 2426 module. One of these pins must be connected to the +24V supply, while the other may be used to route incoming +24V out to an external load.
5	PWR1	Optional positive DC power #1, referenced to GND.
6	PWR2	Optional positive DC power #2, referenced to GND.
7	PWR3	Optional positive DC power #3, referenced to GND.
8	PWR4	Optional positive DC power #4, referenced to GND.
9	PWR5	Optional positive DC power #5, referenced to GND.
10	+5VOUT	+5V output from module’s internal DC-DC converter, referenced to GND. This may be used to supply a modest amount of power to external 5VDC loads.

The pin names shown in Table 2 are silkscreened onto the module for easy identification.

3.2 Module Power

An external 24VDC power supply must be connected to the TB to supply operating power to the module. Module operating power may be applied across any TB pins labeled +24V and GND.

The TB has two GND pins and two +24V pins; these are duplicate connections (i.e., both +24VDC pins are electrically shorted together, as are both GND pins) that may be used to route the applied 24VDC module input power back out to external loads in daisy chain fashion.

 **PWR** lights continuously when 24VDC power is correctly applied to the module and the module’s internal 3.3V DC-DC converter is operating normally.

3.3 Auxiliary/Interlock Power

In addition to the required 24VDC supply, up to five auxiliary DC power supplies may be connected to the TB on circuits labeled PWR1 to PWR5. All of these power sources are optional; none are required for module operation. If any of these circuits are not used, simply leave the associated TB pins disconnected.

All auxiliary power supplies must be positive with respect to the module’s power supply GND. Also, the returns of all auxiliary power supplies must be connected together and to the module’s 24VDC operating power return.

3.3.1 Internal Power Bus

All of the module’s power input signals—including +24V module power, PWR1 through PWR5, and GND (which is common to all power input signals)—comprise the module’s internal power bus. The power bus is routed to the Interlock Power Routing Matrix (see Figure 2) so that any signal on the power bus can supply power to any digital output channel.

Power sources connected to PWR1 through PWR5 may be routed through interlock contacts, and they may have output voltages less than +24VDC. These auxiliary circuits are used to connect alternative power sources to specific digital output channels in cases where such channels require:

- Positive DC operating voltage less than +24V (e.g., +5V, +12V).
- Interruptible DC operating voltage (i.e., interlocked), to guarantee fail-safe shutdown.

3.4 5VDC Output

The TB pin labeled “+5VOUT” brings out +5V power from the module’s internal DC-DC converter. This may be used to supply 5VDC power to external loads.

Chapter 4: Network Interface

The 2426 module connects to a network through its Ethernet interface. This interface supports 10/100 Mbps networks with automatic speed detection. Ethernet provides several important advantages over other popular communication interfaces, including:



- Platform independence.
- Protection from hardware obsolescence.
- Elimination of disruptive ground loops in the client-server communication path.

4.1 Ethernet Connections

An RJ-45 jack (ETH connector in Figure 2) interfaces the module to a 10BaseT/100BaseTX Ethernet network. A Category-5 shielded or unshielded twisted pair (STP or UTP) patch cable—which is not supplied with the module—must be plugged into this jack.

Use a standard patch cable if you are connecting the module to a switch, hub or router. Use a crossover cable if the module will be directly connected to a dedicated Ethernet client.

Two LED indicators are located near the ETH connector:

-  **LNK** lights continuously when incoming link pulses are detected.
-  **ACT** lights briefly when incoming Ethernet packets are detected.

4.2 HTTP Server

The module implements an embedded HTTP server and web site. The web site makes it possible to configure the module and control most of the module's I/O interfaces from a web browser.

The module's web site is intended for module configuration and diagnostic uses. Due to the non-deterministic character of HTTP, as well as the complex parsing it would entail, HTTP is not recommended for automated client applications.

4.3 Telnet Server

A built-in telnet server provides the principal means for controlling the module's I/O resources from automated client applications. Because it is based on plaintext messages, telnet also serves as a practical alternative to HTTP for manually controlling the module.

The module's telnet server supports multiple concurrent telnet sessions, each with a private, dedicated shell. The shells, in turn, provide access to a variety of plaintext shell commands. Network clients interact with I/O devices by sending shell

commands, and receiving the output of shell commands, over telnet.

Upon receiving a shell command from a network client, the module executes the command—often causing manipulation of an I/O interface—and then returns any requested data to the client. In most cases, a client will open a telnet session and leave it open until it has completely finished communicating with the module (e.g., when the client application closes).

Every telnet client can access all of the I/O resources on the module, except that only one telnet client may be connected to the serial COM port at a time.

Applications may have any number of open telnet sessions on a module, up to the maximum number supported by the module. This is a flexible arrangement that makes possible a wide range of configurations. For example:

- A host computer could employ a telnet session for automated module control while, at the same time, a portable laptop computer employs another session for diagnostic monitoring.
- Multiple host computers—each responsible for managing specific I/O resources on a 2426 module (e.g., one for COM port, one for analog/digital/encoder I/O)—can concurrently communicate with a specific module over independent telnet sessions.
- A module's telnet clients need not reside on different host computers; a single host may run multiple threads or processes, each of which has a private telnet session.

4.3.1 Telnet Time-outs

Each telnet session has a programmable time-out interval that specifies the maximum time allowed between consecutive shell commands. If no shell commands are received within the time-out interval, the telnet server will automatically close the session and optionally reset select I/O interfaces to their default states.

The module's telnet time-out function serves two purposes:

- **Crash recovery.** If a client terminates a telnet session in an “ungraceful” way (e.g., application crash), the server will time-out the session, thus freeing it for re-use. This is a critical feature in systems with deeply embedded 2426 modules.
- **Safety.** Malfunctioning hardware or software may cause a telnet client to cease communicating with the 2426. In such cases, the telnet server will time-out and force the outputs of various module interfaces to their “safe” states.

All telnet sessions begin with a default time-out interval and disabled time-out reset. Once the session is running, the client can issue a “WTO” shell command to change the interval and specify whether to reset the module upon time-out.

Chapter 5: Analog Interfaces

5.1 Analog Inputs

Six 12-bit, analog input channels are provided to enable measurement of up to six external voltages. Each channel implements a fully differential input pair so that either single-ended or differential voltage measurements may be made on any channel. Unused channels may be left disconnected. External analog channels are numbered 0 to 5.

Figure 3: Analog Input Interface Block Diagram

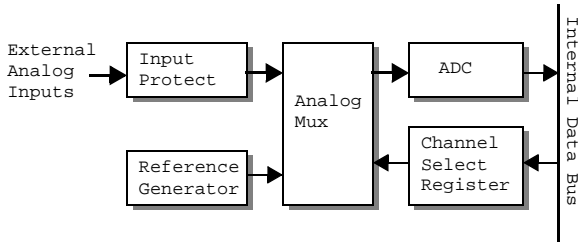

All analog inputs have a fixed input voltage range of $\pm 10V$ with nominal 12 bit resolution. The analog input span extends slightly beyond $\pm 10V$ to guarantee a full $\pm 10V$ measurement range under worst-case conditions and to make it possible to digitally calibrate the external channels.

Two internal reference channels supply precision reference voltages (0V and +5V) to the ADC. Data from these references can be used to digitally correct measurement errors caused by aging and temperature variations.

5.1.1 Analog Input Scanning

All analog inputs (external and internal) are digitized by the module once per millisecond. This scanning process runs continuously and is independent of client requests for analog input sample data.

When a client requests analog input data, the module returns the most recent sample values for each channel along with timestamps that indicates when the samples were acquired.

5.2 Analog Output

One 12-bit analog output channel (AOOUT) is provided, with a fixed output voltage range of $\pm 10V$. This output is well suited for motor speed control or other general purpose uses.

Figure 4: Analog Output Interface Block Diagram

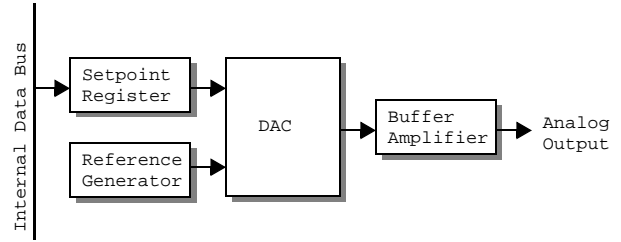

AOOUT is referenced to AGND, so applications that require a differential analog output will typically use the AOOUT and AGND signals as a differential pair.

The voltage produced at AOOUT changes immediately in response to client commands.

5.3 Analog Connector

Analog I/O connections are made through the 25-pin AIO connector (see Figure 2 for connector location). The AIN and AOOUT interfaces both share the AIO connector.

Table 2: AIO Connector Pin Assignments

Pin	Name	Function
2, 4, 6, 8, 10, 12, 13	AGND	Analog ground references for all AOOUT and AIN channels.
15, 17, 19, 21, 23	+24V	+24VDC outputs. These can be used to supply operating power to external loads.
1	+AIN0	AIN channel 0 positive input
14	-AIN0	AIN channel 0 negative input
3	+AIN1	AIN channel 1 positive input
16	-AIN1	AIN channel 1 negative input
5	+AIN2	AIN channel 2 positive input
18	-AIN2	AIN channel 2 negative input
7	+AIN3	AIN channel 3 positive input
20	-AIN3	AIN channel 3 negative input
9	+AIN4	AIN channel 4 positive input
22	-AIN4	AIN channel 4 negative input
11	+AIN5	AIN channel 5 positive input
24	-AIN5	AIN channel 5 negative input
25	AOOUT	Analog output voltage

Chapter 6: Encoder Interface

6.1 Overview

The 2426 module includes a fast, bidirectional counter that is optimized for use with incremental encoders and other high frequency pulse generators. The counter has 32-bit resolution to enable encoder position to be tracked for extended periods without client intervention, and its high speed operation enables high resolution, fast moving encoders to be tracked without errors. The counter is zeroed upon module reset.

Figure 5: Encoder Interface Block Diagram

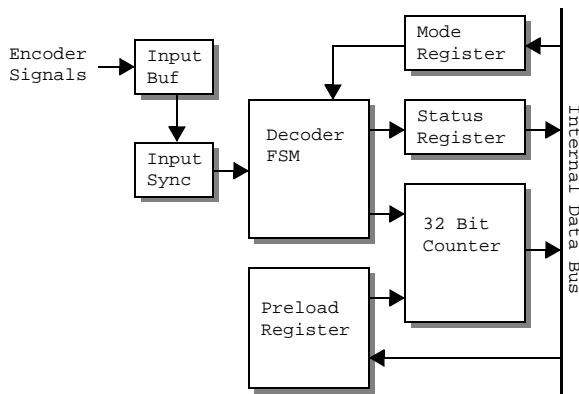

Quadrature encoders commonly generate three signals: two clocks (A and B) and one index, whereas devices such as tachometers produce only a single clock and no index. Some encoders produce an Index output while others do not. The ENC connector supports all three of these signals.

Encoder inputs are first applied to input buffers that accept TTL, 5V CMOS, or differential RS-422 signals. The conditioned inputs are then synchronized to the system clock domain and processed by a quadrature decoder FSM.

The interface includes a preload register which may be loaded with any client-specified 32-bit value. Optionally, the value stored in this register may be synchronously copied into the counter in response to an edge event on the Index input. The Preload register is zeroed upon module reset.

 **ENC** lights briefly when the encoder counter value changes in response to incoming clock pulses.

6.2 Configuration

Before starting encoder operation, the client will typically issue a “WEM” shell command to write to the Mode register. The Mode register is logically partitioned into fields that control various aspects of encoder interface operation:

- **Clock mode/multiplier** specifies whether the interface will operate in quadrature mode (with x1, x2 or x4

multiplier) or non-quadrature mode (basic pulse counting, up count only).

- **Preload enable** specifies whether the occurrence of an active edge on the Index input will cause the counter to be parallel loaded from the preload register.
- **Active index edge** selects either the rising or falling edge of the Index input as the active edge.

6.3 Encoder Connector

The ENC connector (see Figure 2 for connector location) is used to make all encoder connections to the 2426 module.

Table 3: ENC Connector Pin Assignments

Pin	Name	Function
4, 9	GND	Ground reference for encoder power and all encoder signals.
5	+5VOUT	+5VDC output. This can be used to supply operating power to an encoder.
1	+A	Clock A positive input.
6	-A	Clock A negative input.
2	+B	Clock B positive input.
7	-B	Clock B negative input.
3	+X	Index positive input.
8	-X	Index negative input.

6.4 Wiring

6.4.1 Interfacing RS-422 Signals

The encoder interface employs differential RS-422 line receivers to buffer all incoming signals. Each line receiver has “+” and “-” inputs for connecting to a differential signal pair. Use both of these inputs for encoders that employ RS-422 signals, as shown in Figure 6.

Figure 6: Connecting RS-422 Encoder Signals

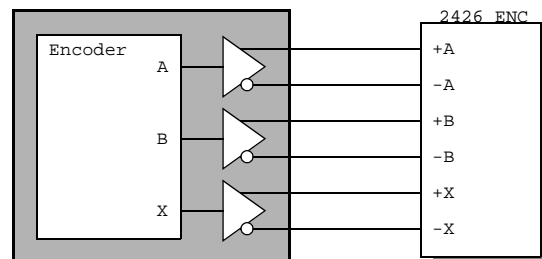

If you are interfacing a single-clock device (e.g., tachometer), connect its clock output to the A clock inputs and leave the ±B clock inputs disconnected. If you are not using the Index signal, leave the ±Index inputs disconnected.

Termination resistors are not supplied with the module. If your encoder (or other signal source) employs RS-422/485 drivers, you may need to supply external terminations near the ENC connector. Refer to your encoder documentation for the recommended practice.

6.4.2 Interfacing TTL/CMOS Signals

To interface to TTL and 5V CMOS compatible single-ended signals, connect only the “+” pin and leave the “-” pin disconnected as shown in Figure 7.

Figure 7: Connecting TTL/CMOS Encoder Clocks

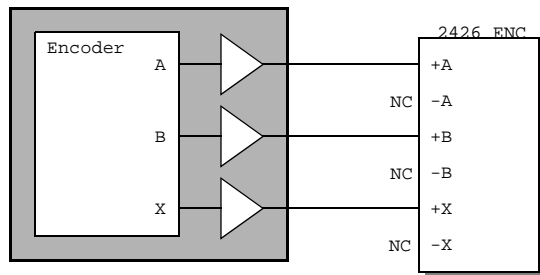

If you are interfacing a single-clock device (e.g., tachometer), connect its clock output to the +A input and leave the -A and ±B inputs disconnected. If you are not using the Index signal, leave ±Index inputs disconnected.

6.4.3 Encoder Power

The +5VOUT and GND pins may be used to power an encoder.



The ENC connector’s GND pin must be connected to the encoder’s power supply return. Failure to connect these returns may damage the 2426 module.

If your encoder (or other pulse-generating device) will be powered from the ENC connector, wire it as shown in Figure 8:

Figure 8: Encoder powered from the 2426 ENC Connector

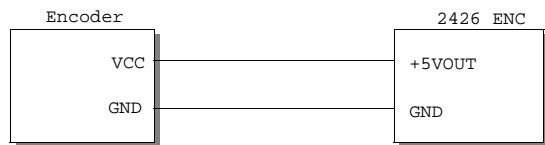

If your encoder is powered by an external power supply, connect it as shown in Figure 9. Make sure the encoder’s ground is wired to the GND pin on the ENC connector.

Figure 9: Encoder powered from an External Supply

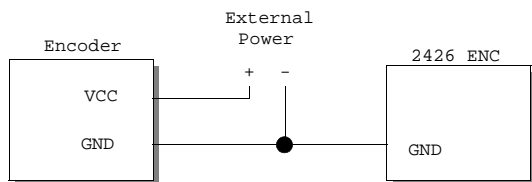

Chapter 7: Digital Output Interface

7.1 Overview

Sixteen general purpose digital output (DOUT) channels are available on the 2426 module. DOUT channels are numbered 0 to 15.

Figure 10: DOUT Channel Block Diagram

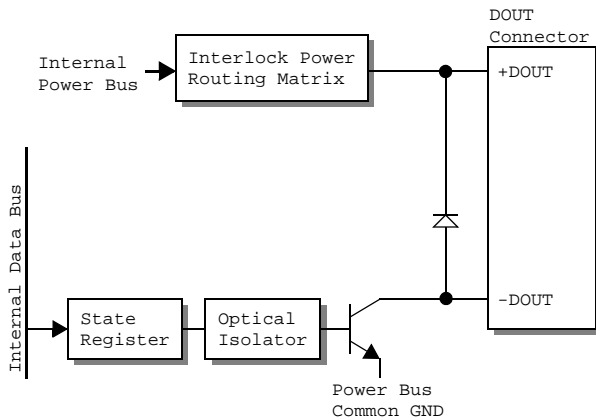

As shown in Figure 10, every DOUT channel has a control circuit that includes a state register, optical isolator, and active-low, open-collector output transistor. The transistor applies the common GND signal to -DOUT when the channel is turned on.

Under software control, each DOUT channel may be configured to operate in either Standard or PWM mode. In the Standard mode (default upon module reset), a channel is programmed to explicit, static states by the network client. When operating in PWM mode, a channel will output pulses having period and duty cycle specified by the network client.

Integral support is provided for system interlock circuits and multiple DIO power supply voltages. Each DIO channel may be powered from any power source available on the module's internal power bus (see "Internal Power Bus" on page 4).

⚙️ DOUT 0-15 - Each of these will light when its affiliated channel is programmed to the "on" state, independent of the channel's operating mode. Note that these reflect the programmed states of DOUT channels; a channel's physical and programmed states may differ if:

- The channel is connected in a "wired-or" topology and its programmed state is off, but an external driver on the same channel is turned on.
- The channel's programmed state is on, but it is powered from an interlock contact that is open.

Upon module reset, all channels switch to the off state and default to the Standard operating mode.

7.2 DOUT Connector

All DOUT loads are connected to the module through the female DB-37 connector labeled DOUT in Figure 2.

Table 4: DOUT Connector Pin Assignments

Pin	Name	Function
1	+DOUT0	DOUT channel 0 positive output
20	-DOUT0	DOUT channel 0 negative output
2	+DOUT1	DOUT channel 1 positive output
21	-DOUT1	DOUT channel 1 negative output
3	+DOUT2	DOUT channel 2 positive output
22	-DOUT2	DOUT channel 2 negative output
4	+DOUT3	DOUT channel 3 positive output
23	-DOUT3	DOUT channel 3 negative output
5	+DOUT4	DOUT channel 4 positive output
24	-DOUT4	DOUT channel 4 negative output
6	+DOUT5	DOUT channel 5 positive output
25	-DOUT5	DOUT channel 5 negative output
7	+DOUT6	DOUT channel 6 positive output
26	-DOUT6	DOUT channel 6 negative output
8	+DOUT7	DOUT channel 7 positive output
27	-DOUT7	DOUT channel 7 negative output
9	+DOUT8	DOUT channel 8 positive output
28	-DOUT8	DOUT channel 8 negative output
10	+DOUT9	DOUT channel 9 positive output
29	-DOUT9	DOUT channel 9 negative output
11	+DOUT10	DOUT channel 10 positive output
30	-DOUT10	DOUT channel 10 negative output
12	+DOUT11	DOUT channel 11 positive output
31	-DOUT11	DOUT channel 11 negative output
13	+DOUT12	DOUT channel 12 positive output
32	-DOUT12	DOUT channel 12 negative output
14	+DOUT13	DOUT channel 13 positive output
33	-DOUT13	DOUT channel 13 negative output
15	+DOUT14	DOUT channel 14 positive output
34	-DOUT14	DOUT channel 14 negative output
16	+DOUT15	DOUT channel 15 positive output
35	-DOUT15	DOUT channel 15 negative output
17,18,19,36,37	NC	Not connected. These are uncommitted pins, reserved for future use.

7.2.1 Load Connections

A channel's output is, in effect, a differential pair consisting of +DOUT and -DOUT. Whenever possible, the load should be connected across these two signals as shown in Figure 11.

Figure 11: Recommended Load Wiring

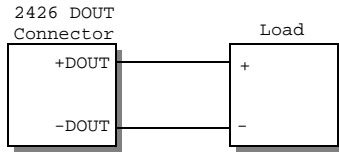

Load impedance must be high enough to limit current on the DOUT terminals to their maximum allowed values. See “Digital Output Interface Specifications” on page 15 for details. In particular, do not short +DOUT to -DOUT as this may damage module circuitry.

7.2.1.1 Output Pull-Ups

The module’s DOUT channel circuits do not have resistors that will pull up -DOUT to the +DOUT potential when a channel is turned off. If a load requires a pull-up resistor, it must be supplied externally as shown in Figure 12.

Figure 12: Load With External Pull-up

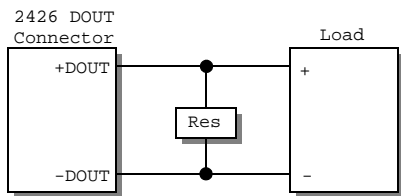

7.2.1.2 Wired-or Operation

The DIO channel output driver is an open-collector transistor, thus it is possible to “wire-or” a channel by connecting its -DOUT terminal to one or more external open-collector drivers. If any driver asserts its active-low output, the channel will be driven to its active state.

7.3 Hardware Configuration

Each channel, or in some cases each group of three channels, is associated with a block of configuration programming posts in the Interlock Power Routing Matrix (IPRM). See Figure 2 for the location of the IPRM. Channels 0 to 6 have a dedicated configuration block per channel, while channels 7 to 9 share a common block, as do channels 10 to 12, and 13 to 15.

Table 5: Shunt Placement on an IPRM Block

PWB Label	Shunt Pins	Selected Power Source
+24V	1-2	+24V power, always on.
PWR1	3-4	Optional positive DC power #1.
PWR2	5-6	Optional positive DC power #2.
PWR3	7-8	Optional positive DC power #3.
PWR4	9-10	Optional positive DC power #4.
PWR5	11-12	Optional positive DC power #5.

Each block of posts has six shunt positions, corresponding to the six signals on the internal power bus. Only one shunt should be installed per block. If a channel will not be used, it is not necessary to install a shunt on its configuration block.

For each channel that will be used, a shunt must be installed on its configuration block to connect its +DOUT terminal to a positive DC voltage supply. This establishes the high side voltage for the channel and enables the built-in protection diode to suppress induced EMF from inductive loads. Also, in cases where the selected power signal is sourced through an interlock contact (e.g., emergency stop switch, oven door interlock), the channel will automatically power down its load when the interlock contact is open.

7.3.1 Example

Figure 13 illustrates a system in which:

- PWR1 receives power through two series-connected emergency stop contacts. Any DIO that is configured to use PWR1 (i.e., a shunt is installed on its IPRM at pins 3-4) will deactivate if either ESTOP contact is open.
- PWR2 receives its power through a safety interlock contact on an oven door. Any DIO that is configured to use PWR2 (i.e., a shunt is installed on its IPRM at pins 5-6) will deactivate when the oven door is open.

All DIOs configured to use the +24V “always on” power source will be unaffected by interlock contacts. PWR3, PWR4 and PWR5 are not used in this application, and so are left disconnected.

Figure 13: Wiring Example With Interlocks

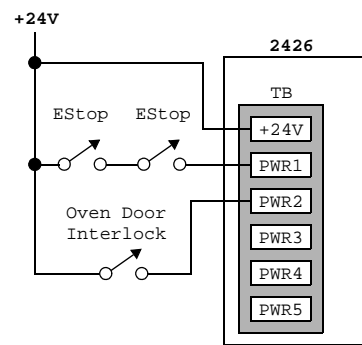

Chapter 8: Digital Input Interface

8.1 Overview

Eight general purpose digital input (DIN) channels are available on the 2426 module, numbered 0 to 7.

Figure 14: DIN Channel Block Diagram

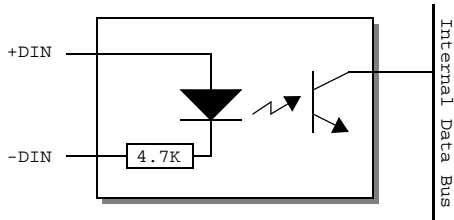

As shown in the simplified block diagram of Figure 14, each DIN channel has an input circuit consisting of a resistor and LED connected in series. When a sufficiently large DC voltage is applied across the input—thus driving current through the LED—the channel switches to its on state. The channel is off when no current is flowing through the LED.

Figure 15: Typical Application

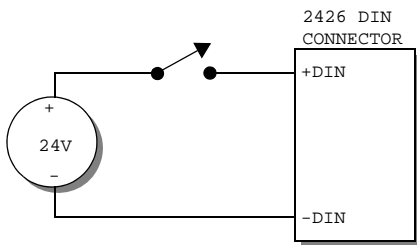

8.1.1 Debounce

The module's internal CPU periodically samples the DIN channels. As each new channel sample is captured, it is stored in a ring buffer. The ring buffer accumulates samples over a debounce interval that spans multiple sample periods. Every sample period, the CPU computes a debounced state for each channel based on the contents of its ring buffer. After changing state, an input signal must maintain a steady state for at least the debounce interval in order for the state change to register as debounced data.

Network clients can access both the raw (non-debounced) and debounced DIN states, as required by the application. Raw states are captured on demand when requested by a client. Debounced states are delayed by the debounce interval plus up to one sample period.

8.1.2 State Indicators

One state indicator is provided per channel to indicate the debounced input signal level for that channel:

 **DIN 0-7** - Each of these will light when current is driven through its associated channel inputs by an external signal generator.

8.2 DIN Connector

Digital input connections are made through the 37-pin DIN connector (see Figure 2).

Table 6: DIN Connector Pin Assignments

Pin	Name	Function
20	+DIN0	DIN channel 0 positive input
2	-DIN0	DIN channel 0 negative input
22	+DIN1	DIN channel 1 positive input
4	-DIN1	DIN channel 1 negative input
24	+DIN2	DIN channel 2 positive input
6	-DIN2	DIN channel 2 negative input
26	+DIN3	DIN channel 3 positive input
8	-DIN3	DIN channel 3 negative input
28	+DIN4	DIN channel 4 positive input
10	-DIN4	DIN channel 4 negative input
30	+DIN5	DIN channel 5 positive input
12	-DIN5	DIN channel 5 negative input
32	+DIN6	DIN channel 6 positive input
14	-DIN6	DIN channel 6 negative input
34	+DIN7	DIN channel 7 positive input
16	-DIN7	DIN channel 7 negative input
1,3,5,7,9,11,13,15,17	+24VOUT	+24V outputs, referenced to GND. These can be used to power modest external loads.
21,23,25,27,29,31,33,35	GND	System GND reference.
18,19,36,37	NC	Not connected. These are uncommitted pins, reserved for future use.

Chapter 9: Serial Communication Interface

9.1 Overview

The 2426 module includes an asynchronous serial communication port (comport) that can be configured to operate with an RS-422 or RS-485 physical layer over twisted-pair cable. Standard data rates are supported up to 115.2 Kbaud.

The comport can be accessed by a network client through the module's telnet server. After opening a telnet session to the 2426 module, the client attaches the session to the comport by issuing a "COM" shell command. The server will respond by sending a shell prompt and, from that point on, all incoming comport traffic will be forwarded to the telnet client and all characters sent to the telnet server will be transmitted on the comport's serial output.

 **COM** lights briefly when a character is sent or received on the comport interface.

At any given time the comport can be attached to only one telnet session. When the comport is already attached to a telnet session, attempts to attach it to another session (i.e., issuing a "COM" command to a different shell) will fail and return an error message.

It is not possible to access the comport through the module's embedded HTTP server.

Remote serial devices sometimes require binary data streams. To accommodate such devices, the 2426 implements the Telnet Binary Transmission Option. Refer to RFC 856 for details.

9.2 Configuration

9.2.1 Hardware Configuration

The comport's physical layer is selected, and on-board line termination resistors are enabled or disabled, by installing hardware shunts onto the COM Configuration Posts (see Figure 2). Shunts may be installed in any of the following combinations ("•" indicates installed shunt):

Table 7: Valid Configuration Shunt Combinations

Shunts				Function
TTERM	RS422	RS485	RTERM	
	•	•		RS-485, unterminated
•	•	•		RS-485 with termination
				RS-422, unterminated
•				RS-422 with TX termination only
			•	RS-422 with RX termination only
•			•	RS-422 with TX and RX termination

9.2.2 Software Configuration

Except for physical layer and line terminations, all comport configuration settings are controlled through the comport's attached telnet session.

Some software configurable attributes (e.g., baud rate and parity) are specified as arguments in the COM shell command. These serve to establish an initial configuration for the comport before it starts operating. In many applications, no additional software configuration is required.

After issuing the COM shell command, all software configurable attributes, as well as special control functions such as BREAK transmission, can be dynamically controlled by means of the Telnet Com Port Control (CPC) option. This protocol is also used to receive notification of errors (e.g., parity, framing, overrun) and incoming BREAK signals, etc. Refer to RFC 2217 for details.

Flow control between the comport and its network client is managed through the Telnet CPC protocol. Flow control between comport and remote serial devices is not supported.

9.3 COM Connector

A female DB-9 connector (COM connector in Figure 2) is used to connect the comport to an external RS-422/RS-485 device or network.

Table 8: COM Port Connector Pinouts

Pin	Name	Signal Function
2	TX-	Transmit, active low
3	RX-	Receive, active low
5	GND	Signal reference.
7	RX+	Receive, active high
8	TX+	Transmit, active high
1,4,6,9	NC	Not connected. These uncommitted pins are reserved for future use.

9.4 Wiring

Shielded cable is recommended for communication cables, although unshielded cables may provide satisfactory performance. If shielded cable is used, the shield conductor should be connected to ground at one end of the cable and left disconnected at the other end. This will provide the benefits of shielding without introducing ground loops.

The 2426 comport can connect to a single remote serial device or a network of remote devices. Some common device network topologies and examples are discussed in the following paragraphs. All of these examples assume the 2426 module is acting as a master on the device network.

9.4.1 RS-422 with a Single Master

In this case, the 2426 module is the sole master of the device network and one or more remote slaves reside on the network. No other devices are permitted to transmit on the master's transmit pair. Figure 16 shows a network of this type with two slave devices.

Figure 16: Single-master RS-422 device network

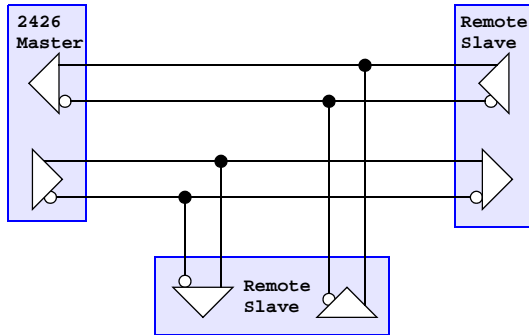

Multiple slave devices must never simultaneously drive the master's receive pair. This is typically ensured by assigning unique addresses to the slaves and programming them so that they will drive the master's receive pair only when responding to directed command messages from the master.

9.4.2 RS-422 with Multiple Masters

In a multi-mastered device network, the 2426 comport shares its transmit pair with one or more remote masters. Figure 17 shows an example of this in which the device network has two masters and one slave.

Figure 17: Multi-mastered RS-422 device network

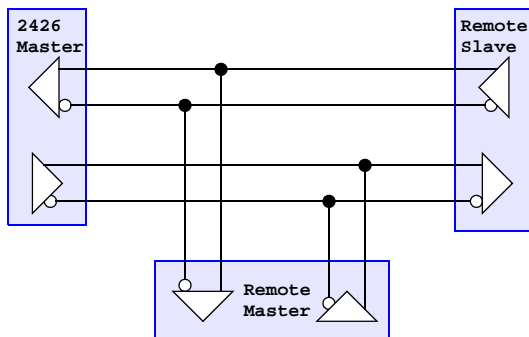

Care must be taken to ensure that masters do not drive their shared transmit pair at the same time, as transmitter collision detection is not available in this configuration.

9.4.3 RS-485

RS-485 networks employ a single pair for both transmit and receive. Only one transmitter is permitted to drive the common pair at a time. Figure 18 shows an RS-485 network

with one master (the 2426) and two slaves, although it is possible to utilize more than one master on a device network.

Figure 18: Single-master RS-485 device network

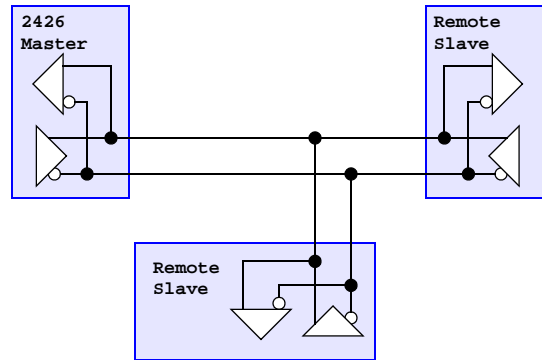

Chapter 10: Specifications

Table 9: Communications Interface Specifications

Network	Physical layer	10BaseT, 100BaseTx Ethernet
	Bit rate	10/100 Mbps, auto-detecting
	Isolation	1500Vrms
	Protocols	ARP, ICMP, IPv4, TCP
	Configuration	Programmable via HTTP (static ARP): IP address, netmask, gateway
HTTP Server	Concurrent sessions	0 to 1
	Functions	Status, configuration, I/O monitor/control
TELNET Server	Concurrent sessions	0 to 3
	Time-out interval	5 minutes (default, programmable via HTTP), programmable per session via shell
	Telnet protocol options	Telnet Binary Transmission (RFC 856) Telnet Com Port Control (RFC 2217)
Async Serial COM	Physical layer	RS-422 or RS-485, shunt configurable
	Bit rate	300 bps to 115.2 Kbps, software selectable
	Termination (RS-422/485)	120 ohms $\pm 5\%$, transmit and/or receive pair, shunt configurable
	Receiver turnaround	250 μ s maximum

Table 10: Timestamp Generator Specifications

Timestamp Generator	Count rate	1.0 MHz
	Temperature stability	± 200 ppm/ $^{\circ}$ C
	Resolution	32 bits (1.0 μ s)

Table 11: Encoder Interface Specifications

Encoder Interface	Resolution	32 bits
	Count rate	0 to 30 MHz
	Clock rate	Quadrature: 0 to 7.5 MHz at 90 degree phase angle, derate for other phase angles Non-quadrature: 0 to 15 MHz, 33.33 ns minimum pulse width
	Clock/Index input signals	RS-422 differential, TTL/5VCMOS compatible, ± 7 V CMV maximum
	Encoder power output	5VDC $\pm 5\%$, 100mA maximum
	Data format	Signed 32-bit integer with timestamp

Table 12: Analog Input Interface Specifications

Analog Inputs	Channels	6 external, 2 internal reference
	Resolution	12 bits
	Input type	Differential
	Differential input range	-10V to +10V, minimum (at 0V CMV)
	CMV input range	-10V to +10V
	Input impedance	22M ohms minimum
	Conversion rate	1000 samples/second, per channel
	Inter-channel acquisition skew	125 μ s maximum
	Trigger	Internal hardware timer
	Data format	Signed 16-bit integer with timestamp

Table 13: Analog Output Interface Specifications

Analog Output	Resolution	12 bits
	Output range	-10V to +10V, minimum
	Settling time	500 μ s maximum (20V step change)
	Data format	Signed 16-bit integer

Table 14: Digital Input Interface Specifications

Digital Inputs	Channels	8
	Input type	Differential, optically isolated
	On state input voltage	+4.5 to +25.2 VDC
	Off state input voltage	0.0V to +0.8 VDC
	Input impedance	4.7 Kohm
	Input isolation	250V, minimum
	Sample rate	1 KHz, per channel
	Debounce period	5 milliseconds
	Current, +24VOUT terminals	100 mA maximum per channel, 500 mA maximum total

Table 15: Digital Output Interface Specifications

Digital Outputs	Channels	16
	Output type	Active low, open collector with EMF suppression diode for inductive loads
	Output high-side voltage source	Internal, shunt selectable from internal power bus
	Current, \pm DOUT terminals	100 mA maximum per channel, 500 mA maximum total

Table 16: Power and Environmental Specifications

Module Power	Input power	24VDC \pm 5% @120mA (digital outputs off, no external loads)
Interlock Power	Channels	5
	Voltage range	+5VDC to +24VDC, referenced to module input power
	Current	500mA maximum, per circuit
Auxiliary +5VOUT	Voltage	+5VDC \pm 5%, referenced to module input power
	Current	100mA maximum
Temperature	Operating range	-25 to 85°C

Table 17: Mechanical Specifications

Module Dimensions	Outer dimensions	5.0H x 5.3W x 2.2D inches. W = overall DIN rail length. D = module height from DIN rail back panel; additional clearance required for field wiring.
Mating Connectors (*) = included with module	ETH	RJ-45 plug, AMP 554169 or equivalent
	TB (*)	Pluggable terminal block, Phoenix Contact 17.92.83.8 or equivalent
	COM	DB-9 male, Norcomp 171-009-102-001 or equivalent
	ENC	DB-9 female, Norcomp 171-009-202-001 or equivalent
	AIO	DB-25 female, Norcomp 171-025-202-001 or equivalent
	DIN	DB-37 female, Norcomp 171-037-202-001 or equivalent
	DOUT	DB-37 male, Norcomp 171-037-102-001 or equivalent